



Stainless Metal Craft (Aust) Pty Ltd
6 Bromley Road, Emu Plains NSW 2750
P. 02 4735 5666 F. 02 4735 7950
E. info@smcstainless.com.au
www.smcstainless.com.au

WASH TROUGHS

FLUSHLINE TROUGH

FLT2



FEATURES

- Internal Radius Corners for ease of Cleaning
- Designed for Flush Mounting into Benchtop
- Flushline Fixing Clamps Supplied
- 50mm Plug & Waste Supplied

OPTIONS

- Custom made – Length & Drainage will vary depending on your application & Client. Please consult our Office
- Design profile to suit your Special Application



WASH TROUGHS

FLUSHLINE TROUGH

FLT2

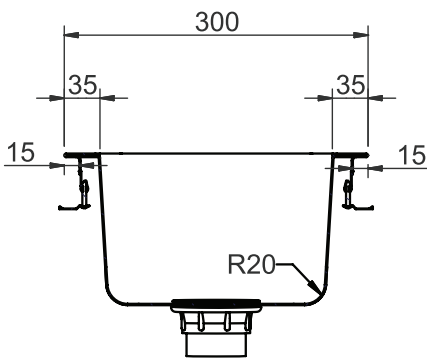

The Bench Top cutout size, to suit the Trough unit, is 20mm less than the overall dimensions of the Trough, and with a maximum corner radius of R25mm

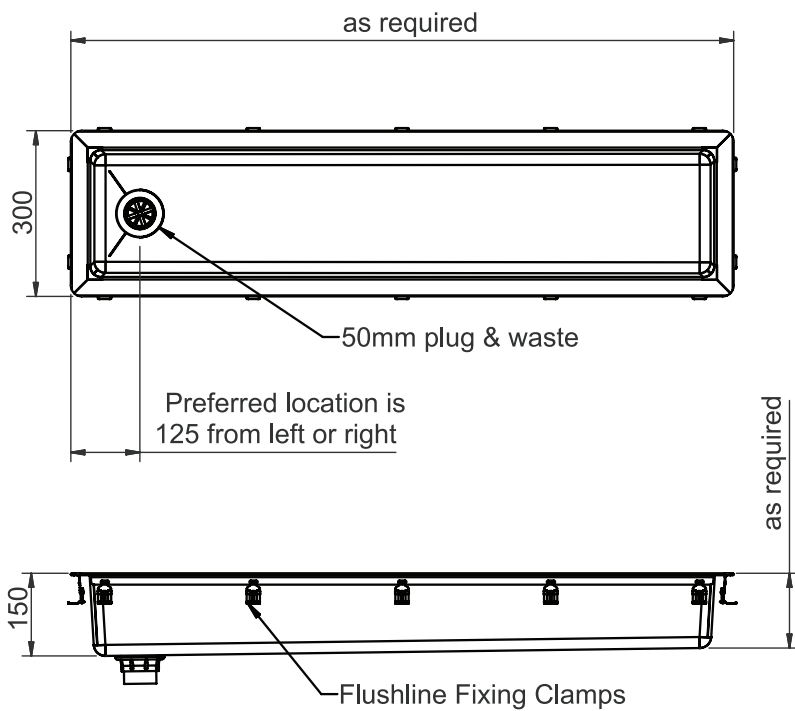

SPECIFICATIONS

Stainless Steel Flushline Trough shall be Model FLT2 from Stainless Metal Craft.
Phone 02 4735 5666